

PROCOS with the Beckhoff Bus Terminal system

The Bus Terminal system

The I/O signals are wired decentralised to fieldbus devices or centrally to the controller. The available manufacturer-specific fieldbus devices with fixed input/output configurations and design often make it necessary to use an entire group of devices with similar functions. This costly method of signal acquisition gives rise to high material, installation, planning and documentation costs as well as high costs for subsequent modification or expansion. Inventory management and service staff are put under unnecessary strain.

Flexible and stable

The Beckhoff Bus Terminal is an open and fieldbus-neutral I/O system consisting of electronic terminal blocks. The head of an electronic terminal block is the Bus Coupler with the interface to the fieldbus. Bus Couplers are available for the following bus systems (when attached to the PROCOS Industrial Process Controller (IPCxxx):

- Modbus, the open fieldbus
- Ethernet TCP/IP, the network bus (used with the Modbus protocol)

Automation standard

The Beckhoff Bus Terminal ensures that control cabinets and terminal boxes are constructed more economically. Using the 4-wire terminating system, all of the usual sensors and actuators with different types of signal can be connected directly without other connection systems. It is no longer necessary to wire the field devices between the first terminal connection in the control cabinet or in the terminal box and the controller. This significantly reduces the costs involved in controller design and saves space, material, work, and money.

The field devices can be wired using the Beckhoff Bus Terminal system on site where the signals occur. Installation and wiring of the Beckhoff Bus Terminal is thus simple and compact like that of a standard terminal block. The Bus Terminal can be connected to the controller by connecting a Bus Coupler via the fieldbus as required.

The Beckhoff Bus Terminals have been tried and tested in a wide range of sectors worldwide, from machine construction to building management. Beckhoff Bus Terminal technology makes design, construction, wiring, commissioning and maintenance of equipment and machines very cost-effective.

System characteristics

Design

The robust housing, secure contacts and the solidly built electronics are prominent features of our components. A station consists of one Bus Coupler and up to 64 electronic terminal blocks.

The electronic terminal blocks are clipped onto the Bus Coupler. They connect by simply latching together. This means that each electronic terminal block can be exchanged separately and can be mounted on a standard mounting rail. In addition to horizontal type mounting, all other mounting types are permitted.

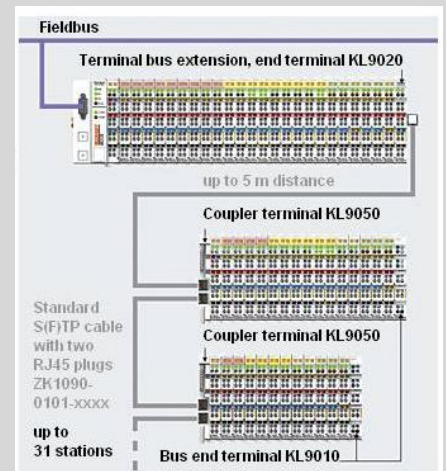

Specification subject to be changed without notice

2008

The Beckhoff Bus Terminal with its outside contour adjusts perfectly to the measurements of terminal boxes. The clear front panel of the terminal with light-emitting diodes for status display, plug-in contact labelling and detachable labelling fields guarantee clarity. The 3-wire system supplemented by a protective conductor terminal makes it possible to wire sensors/actuators directly.

Free mix of signals

The Beckhoff I/O system supports more than 180 Bus Terminals and is thus probably the most comprehensive system on the market. The components enable users to operate mixed signal configurations without restriction at each station. This means that a single non-central input/output node can map all the necessary signals.

Appropriate Bus Terminals are available for any digital or analog automation signal type, for currents and voltages with standardised signal levels and for PT100 and thermocouple signals.

The fine granularity of the Bus Terminals enables bit-precise composition of the required I/O channels. The digital Bus Terminals are available as 2-, 4- or 8-channel terminals. The standard analog signals of 0 ... 20 and 4 ... 20 mA are all available as 1-, 2-, 4-, and 8-channel variants within a standard housing. In the 8-channel variant, analog input and output signals are arranged in an ultra-compact way within a standard Bus Terminal housing across a width of only 12 mm. The system is thus highly modular and can be projected cost-effectively with accuracy down to a single channel.

The terminal modules with plug-in wiring combine 16 or 32 digital I/Os within a very small space and with high packing density.

Economical and small

For the user, Beckhoff Bus Terminals offer independence from the particular fieldbus and terminal block design. Digital and analog signals can be mixed without restriction, starting with one or two signals per terminal. Beckhoff Bus Terminals replace manufacturer-specific designs and all the intermediate terminal positions. The Bus Terminal ensures transparency and flexibility. Distributors and terminal boxes become smaller, more economical, and in some cases can be omitted. Plants and machinery equipped with Beckhoff Bus Terminals offer significant competitive advantages.

Project engineering and parameterisation

If the KS2000 configuration software from Beckhoff is used, the Bus Couplers (BK7300/9000) can be configured with the necessary communication parameters before they are connected to the PROCOS Industrial Controller (IPCxxx).

Documentations for all Bus Couplers and Bus Terminals are available from the Beckhoff download pages.

Specification subject to be changed without notice